

Pododermatosis: what are the prospects for control?



 brighton and sussex
medical school



Dr Gail Davey
Reader in Global Health,
Brighton & Sussex Medical School
and
Honorary Associate Professor,
Addis Ababa University, Ethiopia

Podoconiosis: definition

Podoconiosis from the Greek *podos* (foot) and *konos* (dust).

Tropical elephantiasis, distinct from lymphatic filariasis (LF).

Geographically localized, 'endemic non-filarial elephantiasis'.

Ascending, commonly bilateral but asymmetric, lymphoedema.



Pathogenesis 1868-1970:

distinction from other causes of elephantiasis

1868-1890s: Role of filaria
(Wucherer, Lewis, Manson, Bancroft)

1938: No filaria (Robles in Guatemala) -
'disease associated with walking barefoot'

1960s: No filaria/onchocerciasis (Oomen in Ethiopia)
Altitude between 1000m and 2000m

1970s: No parasite or bacterium (Price in Ethiopia)
Epidemiological and geological mapping

Pododermatitis – what is it?

‘Gene-environment interaction’ -
Gene + soil exposure
= disease
Susceptible people
who go barefoot
have high risk of
disease.

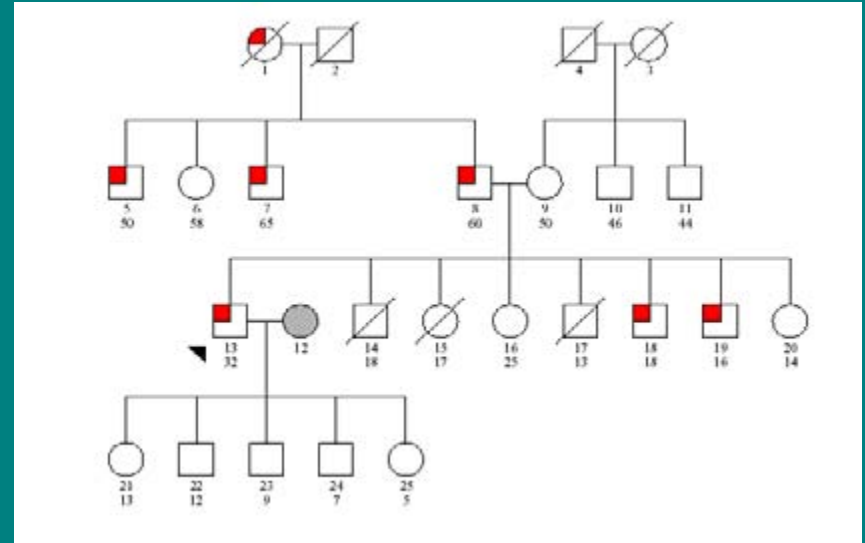

Global Distribution



Distribution in Africa

Environmental niche –

- >1200m altitude
- >1000mm rainfall annually
- Red clay soils

Distribution synergies with other NTDs –

- Soil-transmitted helminths;
- Trachoma

Found in the poorest rural communities where people have long term exposure to soil & cannot afford shoes.



Microsoft® Encarta® Encyclopedia 2002. © 1993-2001 Microsoft Corporation. All rights reserved.

Disease Burden

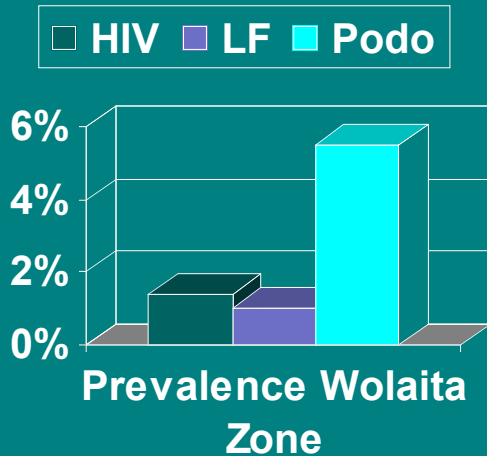

5-10% prevalence in areas of irritant soil & subsistence farming.

Est. 1 million people affected in Ethiopia, 0.5m in Cameroon.

(Desta et al, 2003; Wanji et al 2008)



Profound social stigma

(Wanji et al 2008, Yakob et al 2009)

Total cost in Wolaita zone:
US\$16m per annum.

(Tekola et al, 2006)

Total est. cost to Ethiopia:
US\$200m per annum.

Why 'Neglected'?

- Confusion with LF persists, even in areas where there has been clear documentation of lack of filaria (eg NW Cameroun);
- Tropical, but non-infectious;
- Long term exposure necessary – tourists and military will not be affected;
- Disease of the most voiceless remote communities.

Primary Prevention

Education through schools, churches, mosques,
administrative meetings, events;
Provision of subsidized or free shoes



Secondary Prevention

Treatment using foot hygiene, soap, antiseptic, ointment, pressure bandages, socks and shoes seems effective in reducing stage of disease, leg circumference and life quality (Sikorski et al, PLoS NTD)



Simple Treatment is Effective

Before



After



Tertiary Prevention

As for secondary prevention, plus occasional nodulectomy. Social & spiritual rehabilitation to -

- Restore a sense of worth and community;
- Diminish family & community stigma;
- Generate income without contact with irritant soil.



Management Synergies with other NTDs

Shoes will also prevent

- STH;
- Tetanus;
- Madura foot
- Snakebite.

Foot hygiene almost identical to that of LF
lymphoedema.

Prospects for Control of Dahlem Workshop Criteria

1. Biological & technical feasibility

- Aetiologic agent, Nonhuman reservoir, Effective intervention tool, Effective delivery strategy, Simple/practical diagnostic, Sensitive surveillance, Field-proven strategies.

2. Costs and benefits

- Cases averted per year, Coincident benefits, Intangible benefits, Estimated annual direct global savings, Estimated total external financing.

3. Societal and political considerations

- Political commitment, Societal support, Disease burden in politically unstable areas, Core partnerships and advocates, Technical consensus, Donor base. (Aylward et al, 2000)

Biological & technical feasibility

Aetiologic agent	Mineral*Gene(s); but neither clearly defined.
Non-human reservoir	None
Intervention tool	Requires better demonstration of effectiveness ie RCTs
Delivery strategy	Patient-led strategy successfully replicated on small scale in W & N Ethiopia
Diagnostic	Exclusion of LF
Surveillance	Nil yet, but feasible
Field-proven strategies	Only small scale

Costs & benefits

Cases averted per year	Requires formal evaluation
Coincident benefits	Improve water supply; health education; increase hygiene practices.
Intangible benefits	Social equity: focussing attention of decision makers on poor, remote, rural populations
Estimated annual direct global saving	Cost-benefit and cost-effectiveness analyses essential
Estimated total external financing	Requires formal evaluation

Societal & political considerations

Political commitment	Still weak
Societal support	Almost non-existent
Disease burden in politically unstable areas	Eastern Congo
Core partnerships and advocates	Being formed
Technical consensus	Requires stronger scientific evidence
Donor base	Attractive – a ‘low-hanging fruit’

Urgent Next Priorities

1. Disease mapping

- Tropical Africa;
- Central & South America;
- North India;
- Within suspected high burden countries (Ethiopia, Cameroun, Rwanda)

2. Formal RCTs of intervention (incl. cost-benefits)

- Components of hygiene package
- Prevention using children's shoes

3. Development of international pododermatosis initiative (resource center, advocacy network)

The Podoconiosis Research Team

Institution	Researchers	
Addis Ababa University, Ethiopia.	Henok Legesse, Bereket Yakob, Sisay Addisu, Desta Ayode, Dr Getnet Tadele, Dr Yehesak Worku, Dr Zewdie Ayele, Yordanos Belayneh, Dr Dagnachew Legesse, Dr Mohammed Umer.	
Brighton & Sussex Medical School, UK.	Dr Gail Davey, Prof Melanie Newport, Dr Chris Finan, Dr Mike Titheradge, Dr Tony Williams, Prof Bobbie Farsides.	
Wolaita Sodo University & MFTPA, Ethiopia.	Meskele Ashine, Zewdie Zeleke, Ababayehu Tora, Dr Dereje HaileMariam, Dr Fekadu Ayele, Dr Kelemu Desta.	
Armauer Hansen Research Institute, Addis Ababa, Ethiopia.	Dr Abraham Aseffa.	
Research Foundation for Tropical Diseases and Environment, Cameroon.	Prof Samuel Wanji, Dr Nicholas Tendongfor, Jonas Arnaud Ouafu Kengne, Doris Nnam.	
National Institutes for Health, Bethesda, MD, USA.	Dr Fasil Tekola, Prof Charles Rotimi, Dr Adebowale Adeyemo, Prof Colleen McBride, Desta Ayode.	
Canterbury, UK	Dr Claire Fuller	
Cambridge University, UK	Dr Peter Baxter	
Natural History Museum, UK	Dr Javier Cuadros, Dr Jenn Le Blond	

Acknowledgements

The Wellcome Trust



The Mossy Foot Treatment & Prevention Association



International Orthodox Christian Charities



TOMS



National Institutes of Health, USA

